

IS-1 ISDN Synchronizer NOTES

Simple Synchronization via
DolbyFax ISDN Codecs
Using One or Two IS-1 Units

Tom Scott
EDnet
10/4/2001

e

About These Notes

These notes are not designed to replace the Colin Broad Electronics IS-1 Manual. That volume has a great deal of technical information on the setup, operation, and maintenance of the IS-1, but its format may be a bit difficult if you prefer a less technical presentation.

Hopefully these notes offer a shorter alternative that will serve for many simple applications of the unit. Furthermore, it sometimes helps to have the same material presented from two different approaches, so keep both these notes and the manual at hand.

I've tried to make these notes conversational and sparse, in the hope that you'll read the whole thing. It should take you less than ten minutes, and will be very useful, particularly if you are sitting in front of the unit where you can push buttons and see what happens.

The first three pages are a Quick Start Setup and a short Troubleshooting section.

These are followed by a General Introduction, a discussion of Offsets, and directions for the Setup or Configuration Mode with some menu examples.

Finally, there are some application diagrams that may prove helpful.

If you find some information lacking, please call or e-mail me and I will attempt to make additions and corrections. As I expect to revise these notes occasionally, feel free to ask for an updated copy.

Tom Scott
VP Engineering
EDnet, San Francisco

1-800-93-EDNET (x833)
tscott@ednet.net

One Page Setup for Slave Operation

If you are connecting to someone who has a Colin Broad IS-1 and need to receive timecode and make your local video deck follow them (Slave to their Master), you probably should read all of the attached notes. However, if you are feeling lazy or lucky and you don't want to read much, try the following:

Plug the 9-pin control cable from the Slave Deck into Serial Port B on the IS-1.

With the Remote Control selector on the video deck on Local, play a tape on the video deck. Push the SELECT button on the IS-1 to choose Slave on the display choices. Observe that timecode from your tape is being read in the Slave display window.

Set the Remote Control selector on the video deck to Remote. With the IS-1's CHASE button not pushed and NEAR END control selected, prove that you can control the Slave deck from the the Play/Stop/Rew/FF buttons on the IS-1.

Plug the special 9-pin Y cord from the Dolby Decoder and Encoder into Serial Port A on the IS-1. The Dolby (female 9-pin D connectors) ends of the Y cord are not identical; one goes to the encoder the other to the decoder. See Page 18 of these notes for details.

Make a DolbyFax connection to the studio where the Master IS-1 is installed. If there are several sets of Dolbys at the Master end, be sure that you are dialing into the set with the IS-1 attached. Choose ISDN in the IS-1 display with the SELECT button. Observe that timecode is shown on the display if the Master location is sending timecode.

Press CHASE on your IS-1 and the Slave deck should try to synchronize to the incoming ISDN timecode. If the audio received on the Dolby decoder is not quite in sync, adjust the ISDN Offset with the Trim+ and Trim- buttons.

The illustrative diagrams at the end of these notes may be useful.

If the above does not meet with success, read the troubleshooting tips on the next page. If they don't work for you, read the rest of these notes. Still frustrated? Then call EDnet at 1-800-933-3638 and we'll try to help.

Simple Troubleshooting Tests

On the Master end:

Is the IS-1 set as Master? (Neither READER nor ISDN pushed)

Are you able to see the Master timecode changing when you roll the master machine or controller?

If not, check the wiring from the source of Master Timecode to Reader XLR. If you can't see it at the Master end, there's no point in looking for it at the Slave end.

If you see timecode in the Master display window but the Slave at the other end of the ISDN connection sees different numbers in the ISDN display, check the setting in the Serial A menu on the Master IS-1. If you want to send timecode that you have plugged into the INPUT XLR connector on the Master, you should be set to Send Reader 1 (SndRdr1 not SndS9). For details, see **Setting Up the IS-1** later in these notes.

On the Slave end:

Are you sure that you are set to slave to ISDN (ISDN button pushed in the Master area)? Do you see ISDN code on the display you SELECT the bottom LED position? Early units do not label this LED as ISDN, but it's the bottom one. If not, check the connection to Dolby decoder. Are the Dolby codecs actually connected over ISDN?

Do you see the same code in the Master display SELECTION (modified by any offset that may be programmed in)?

With CHASE not pushed and NEAR END control selected, can you stop and start the Slave deck? If not, look at the 9-pin control from Serial B to the Slave deck. Is the cable correct? Is the deck really controllable with Sony 9-pin RS-422 serial control? Is the deck in REMOTE control mode? Is the correct machine type selected in the SERIAL B menu? When in doubt, try 9850 for standard Sony protocol.

Do you see the Slave machine's timecode changing on the display of the IS-1 when you roll the tape machine under local control? If not, does it have an internal timecode reader that can output over the 9-pin remote control connection? If this is not the case, you will need to bring LTC code from an audio track or from the time code track of the video machine into the AUX-B input of the IS-1. Then, in the Serial B setup menu, select TACH LTC as the Code Source (not SerCode), and select Tnr1 (instead of POSLTC).

If all the above are working, you should be able to press CHASE and the Slave deck will try to synchronize to the incoming ISDN timecode.

Observed Strangenesses and Workarounds

Symptom

The deck “takes off” when you plug in the 9 pin control cable or when you switch the video deck from LOCAL to REMote control, even powering down IS-1 and deck won’t clear the condition. This is caused by the IS-1 being stuck in chase mode, regardless of the front panel indications.

The Cure

Sometimes simply receiving good code over the ISDN Serial A connection will clear the condition. If not, do a Hard Reset by pressing the SELECT and the FREEZE buttons simultaneously. If the unit is so confused that the front panel is locked out, power cycle the unit with the same two buttons pushed. This resets the unit to the factory presets.

Symptom

The video deck eventually locks, but only after 4 or 5 tries, each time doing a locate for a few frames. The effect is that it takes up to ten seconds before the video deck settles down.

Possible Cures

Five things to try (one at a time to avoid confusion):

- 0) Do you have a video reference plugged into the IS-1 and the Slave deck. This is fundamental, and it helps a lot.
- 1) change the setting of the timecode phase in the Serial B Menu from the default, Conn Mid (middle of frame), to Conn StArt (beginning of frame).
- 2) lower the number of tries in the Serial B Menu from the default (tr45 05) to tr45 03.
- 3) try increasing the LOCate speed setting in the Serial B Menu from default 02 to 03 or 04.
- 4) You may need new software. Check your firmware revision. You see the revision number when you power up. Have a pencil handy, as it goes by quickly. See below

Observed Strangenesses and Workarounds, Cont.

Symptom

When you repeatedly press the SELECT button the Display LEDS have a funny (ie. Not top to bottom, step-by step) order.

Cure

If you are not in the SET mode, you need new firmware. Call us.

Symptom

The unit works fine when your Dolby encoder is set to **AC-2**, but it stops working when you change to **AC-3** (DP503/DP524 Dolby units only)

Cure

The AC-3 aux data rate is incorrect. On the DP503, be sure that the data rate in the display is 12 (for 1200 baud). Check the dip switches on the back of the 503 and 524 units: DP503 should have all switches UP; DP524 should have all DOWN except for switch 6 which should be UP. This sets the receive aux data rate to 1200 baud for AC-3. In AC-2 the data rate is always 1200 regardless of the switch setting.

Do You Need New Software?

If your software version (seen for a few seconds as the unit boots up) is 6.0A.77.26 or earlier, you may need a software upgrade; call me (Tom Scott) at 1-800-933-3638 x833 and let's discuss it.

General Introduction

How to think about the IS-1 Synchronizer

Here is a short description of how one Colin Broad IS-1 (let's call it the Master) connects, communicates, and controls another similar IS-1 unit (the Slave) at a remote site.

The Master IS-1 sends time code and machine control commands (like Stop/Start/Rewind, and even Record if you enable it) at 1200 baud down the auxiliary serial port of the ISDN-connected Dolby codecs. This information is passed down the ISDN connection to another IS-1, the Slave IS-1, that is connected to a serially controlled VCR, DAT machine., or AVID video editor (the Slave machine). The Slave machine must employ Sony 9-pin RS-422 serial control. The Slave IS-1 controls the Slave machine and makes it follow the received timecode. Never mind for now exactly how the timecode gets compressed down to only 1200 baud, suffice it to say it's a neat trick and it works.

The timecode that is sent by the Master IS-1 may be internally generated in the IS-1, or, more likely, it may be jammed (copied and regenerated) from external timecode supplied by a local controller like a JSK, Lynx, Adams Smith, Magnatech 8-LB, or from a master audio or video deck. The external timecode is plugged into the Input XLR on the Master IS-1 and the IS-1 encodes the true timecode and sends 1200 baud "encoded timecode" signals through the Dolby encoder and down the ISDN lines, through the Dolby decoder to the Slave IS-1. Tally information from the Slave deck is received by the Slave IS-1 via the 9 pin RS-422 control port and sent back up the lines to the Master IS-1 to indicate the movement of the Slave machine: Play, Stop, FF, Rew, etc.

Am I Master or Slave?

The two button group labeled MASTER is where you to select between the Master and Slave functions. Internally these buttons choose a **Configuration**, but more about that later.

- If neither of these two buttons is selected, the IS-1 acts as the **Master**.
- If one of the two buttons is pushed, the IS-1 will act as a **Slave**.

If Slave, the buttons select how the synchronizer receives the Master timecode: either from the timecode **READER** Input XLR jack, or from a remote Master IS-1 over **ISDN** lines via the Dolby codecs connected to Serial Port A (RS-232).

Serial Port A on the back of the IS-1 connects to the Aux Data ports of the Dolby codecs with a special 9-pin Y-cord supplied by EDnet. Or make your own from the diagram at the end of these notes. If there is a two way connection (ie. there is are both Dolby encoder and decoder at each end of the connection), the Slave IS-1 will send Stop/Play/Rewind tally information back to the Master IS-1. However, the Slave IS-1 can receive and chase the Master timecode even if it is connected to only a Dolby decoder.

Identifying the Controls in the DISPLAY area

- SELECT, the first gray button on the far left of the IS-1, SELECTs which value you will see in the red numerical display window during operation. The choices are Master Timecode, Slave Timecode, any Offset that is programmed in between master and slave, the READER input, or the timecode coming in on the ISDN (Dolby) connection.

- VITC, the second button, may be ignored. You probably do not have the optional VITC reader installed

- SET, the third button from the left, switches between the SET mode and normal reader/synchronizer operation. You know you are in the SET mode when the three periods (decimal points) that separate

hours.minutes.seconds.frames

in the time code window go out and the LED to the left of the word SET comes on.

In the SET mode there will be only one period (dot or point) which acts as a cursor to show which digit you are working on. Change the value with the INCRement and DECRement buttons; in the SET mode these are the sixth and seventh buttons from the left. Move the cursor right and left with the arrow keys (fourth and fifth buttons in the SET mode). The value will be stored when you exit the SET mode by releasing the SET button.

You will not usually need to SET any values for simple synchronization. For future reference, however, in the SET mode you may change these three values:

- the Generator Reset value (SELECTed as Master in the SET mode)
- the difference between Reader and Master (SELECTed as Offset)
- the Reader timecode reset value (SELECTed as Reader)

Identifying the Controls (cont.)

This last value would be useful when JAMming timecode generation with an offset. You might do this if the Master timecode you are generating must have a different hour than the code you are jamming. Jamming timecode means generating new code based on timecode coming into the INPUT XLR or the Serial B 9-pin interface. More about this later in **Offsets** on page 9.

The SET function also allows you to enter parameters into menu lists. This will be covered later in these notes, under the **Setting up the IS-1** heading.

- JAM, the fourth button, enables the JAM mode of generating timecode, locking the internal generator to one of the timecode inputs. At the Slave unit, this may be thought of as enabling or turning ON the synchronizer. Selecting either READER or ISDN as Master should automatically select JAM.

- The fifth button from the left turns on and off the FRAMES Display. It affects only the display. The unit always keeps track of frames even if they are not displayed.

- The sixth button resets the internal timecode generator to a preset value, starting the generator upon the next push of the same button.

- The ISDN Offset and Local Offset button groups set or change the values of timecode offsets, internal mathematical adjustments to the timecode read or generated. More about these in the later section, **Offsets**.

Identifying the Plugs on the Back

INPUT (XLR female) reads Master timecode from the Master controller or deck(s) at the controlling end of the ISDN connection.

Serial A (RS-232) connects to and from the Dolby encoder and decoder Aux Data ports at each end of the ISDN connection. Timecode, machine control commands, and tallies are carried on this port.

Serial B (RS-422) connects to the slave deck (VCR or DAT) being controlled.

Aux B (XLR female) may be used to read timecode from the slave deck if it does not supply timecode over the 9-pin D Serial B connection.

Video reference (BNC) should be connected to a "house-sync" video reference. The video reference is used as a timebase for the internal Master timecode generator or for Slave jam sync applications. For simple synchronizing of a remote deck, the Slave unit must have a video reference since the IS-1 will locate and sync from the received timecode at the Slave end and then release speed control of the slave deck to the video sync reference.

Ext. Ref. (BNC) accepts a frame rate square wave (not video). Special applications only.

Offsets

ISDN Offset(s)

The IS-1 has registers to hold two timecode "ISDN Offsets" that adjust for the encode/decode delay of the Dolby AC-2 audio. The first is used as a "one-way" offset to adjust for the encode-decode time of the codec in use (typically 1 or 2 frames). The second is a "two-way" offset, often twice the "one way" offset (typically 3 to 5 frames). The Dolby AC-2 encode and decode time is approximately 50 msec., or between one and two video frames.

For applications that require sending audio "round trip" out to the distant location and back, you are concerned with both two Dolby encode-decode times as well as the transport time through the ISDN lines. You may need to add a little more offset for the round trip "speed of light" transit time through the phone system. LA to New York is usually less than one video frame, though this depends on the path.

The ISDN Offset values can be adjusted with the Trim- and Trim+ buttons on the front of the unit or SET in the **Serial A** menu (more about that later in the **Setting up the IS-1** section). The ISDN offset is only applied when the timecode is moving, and the only way to see the actual numerical value of this offset (in frames) is in the SET mode, Serial A menu, OFSt1 and OSFt2. One-way offset can accept values between -10 and + 10 frames. Two-way offset is twice that, - 20 to +20 frames.

The ISDN Offset value is added to the timecode sent over the ISDN to the Slave. The offset should be applied at the Master end. You select which offset to use by the button marked 2-WAY. If 2-Way is not pushed, you get the one-way offset. Two-way offset is selected when the 2-WAY LED is lit. The two trim buttons on either side of the 2-WAY button add or subtract a frame from whichever offset is currently selected.

LOCAL OFFSET

There is another Offset register in addition to the two ISDN Offset values. This is the LOCAL OFFSET value. This is the value that you see in the **Local Offset (cont.)** display window when you SELECT Offset. Usually the Local Offset button group on the front panel sets this value. If the Master and the Slave are parked at a sync point, you can push the "MARK" button which will calculate the numeric value of the difference between the timecode master location and the position of the Slave and put that value in as LOCAL OFFSET. The adjacent trim buttons act on that Local Offset value. Pushing both trim buttons at the same time zeros out the Local Offset value.

Like the ISDN Offset, the Local Offset value can be adjusted both with the Trim- and Trim+ buttons on the front of the unit and with the SET function, but this time in the **Serial B** menu (see the **Setting up the IS-1** section). The Local Offset is seen in the Offset display window or the Serial B Menu.

Example: Different Timecode on the Local Tape?

The Local Offset register is used when you have different timecode on the Slave tape from the Master timecode arriving over the ISDN. For example, the Master may be sending 1:00:00:00 (1 hour timecode) but your tape of Reel 3 starts at 3:00:00:00. By parking both the master and the slave at a sync point and pressing the MARK button in the Local Offset group, the IS-1 will calculate and insert an appropriate offset that will take care of that timecode mismatch.

A Local Slave at the Master End

Since the Master IS-1 also includes a complete synchronizer, it can slave a local deck to the Master timecode as well. That is, an audio or video deck plugged directly into the 9-pin Serial B interface on the Master IS-1. Here again, you can use the Local Offset register. Recall, that the Local Offset MARK button grabs or marks the offset between the timecode Master position and the position of the local Slave deck. The adjacent trim buttons act on that Local Offset. Pushing both trim buttons at the same time zeros out the selected offset.

Offset Summary

- The ISDN Offsets (One-way and Two-way) are applied to the Serial A information received from the ISDN lines and they only apply when the machines are moving in CHASE mode.
- The Local Offset is applied to the Serial B link to the machine being controlled by serial 9 pin control.

Slaving to Audio Timecode with Only One IS-1

The IS-1 synchronizer is very slick when slaved to another IS-1 at the far (Master) end, but you may not always have that luxury. Fortunately, the IS-1 can function as a stand-alone chase synchronizer, slaving to received audio timecode from any source. One of the audio channels of the Dolby codec can be used to bring audio timecode in to the XLR INPUT connector on the Slave IS-1. You would press the Master READER button and the CHASE button to enable this type of Slave synchronization.

Setting up the IS-1

The SET Configuration Mode

Enter the Configuration Mode by first pressing SET and then pressing the left and right arrow keys simultaneously. The IS-1 will then offer three menus or groups of parameters (older units may display four):

Unit

Serial A

Serial B

The left/right arrow keys will step from one to the next. To enter one of the three menus, press both arrows simultaneously. Pressing the SET key again will exit from the configuration mode when you are through making changes to that menu item.

UNIT Menu

If you choose the UNIT menu, you will be offered four stored configurations (**CONFIG 1 , 2, 3, 4**) which you may select and/or modify. Think of these choices under UNIT as "personality selections", or variations on Master or Slave. These personality presets will remain in non-volatile memory when the unit is turned off.

Which Config am I using?

Config 1 Is the Master mode. This is automatically selected when neither of the two buttons in the MASTER area are pushed (neither READER, nor ISDN), or Config 1 may be selected in the UNIT menu.

Config 2 is one of the two Slave modes, and is used when you wish to Slave to timecode plugged into the INPUT XLR connector on the Slave synchronizer. Config 2 is automatically selected when you push the READER button in the MASTER group, or it may be selected in the UNIT menu. You would use Config 2 if there is no IS-1 at the Master end. In that case, one of the audio channels of the Dolby codec may be used to bring audio timecode in to the INPUT XLR connector on the Slave IS-1. This is sometimes called "code only master" or "chase" synchronization.

Config 3 is the other Slave mode. It is used when you wish to Slave to timecode coming in over the ISDN/Dolby RS-232 connection. This is the mode that you will use when slaving to another IS-1. It is automatically selected when you push the ISDN button in the MASTER group, or it may be selected in the UNIT menu. The front panel buttons are easier, of course.

Config 4 is used as a generator mode for striping tapes.

The SET Configuration Mode (cont.)

Example: To Set UNIT Configuration Parameters:

Press SET, then both Arrow buttons.

Select UNIT, press both Arrows.

Select CONFIG 1 (for Master) or CONFIG 3 (for ISDN Slave), with left/right arrows, then press both Arrows.

Scroll through Parameters by left or right Arrows, change values for each Parameter by DECrement and INCrement buttons.

G Std	Frame rate: usually 30, film may be 24
GEN rEF	Reference source: usually Video or Reader
Not Col	For NTSC video use Not Colour, 4 and 8 field are for PAL
VitC-Ltc	Normal, VITC Only requires VITC reader, tapes
FRZ diSP	Freeze the display
USERGrSt	Set user bits upon Generator Reset (G.RST button)
JAM rdr1	Jam TC Source: Jam Slave generator from reader
JAM CodE	Jam type: Jam only on good code read after JAM button
Jam OFFS	Jam offset enabled (offset must still be SET)
DroPO 31	number of frames before stopping JAM on no code
bUrST 06	how often to send sequential frames @ hi speed (1 to 30)
SCOdE ON	continue to repeat TC frames on stopped code
SCODE 0	Offset 0 for stationary code (0, or -1 for Adams Smith)
tout 50	Timeout
GENU-PSt	Userbits source: use SET preset value
JAM Loc	Lock the JAM key so that it may not be accidentally changed during synchronizing operation.
dISPrdr1	Display Reader 1 (INPUT) or Reader 2 (AUX B) when the READER display window is SELECTed.

The Serial A Connection

Serial A is the RS-232 connection through the Dolby units that goes out (and comes in) over the ISDN lines. For use with Dolby units, the following are appropriate settings. See the Colin Broad IS-1 Manual or call EDnet for settings for other units (CCS, Telos, APT, Comrex, etc.)

Example: Set Serial A (ISDN RS-232) Configuration Parameters:

Press SET, then both Left and Right Arrow buttons.

Select SERIAL A, press both Arrows.

Scroll through Parameters by left or right Arrows, choose values for each Parameter by DEC/INC buttons.

baud	Baud rate: 1200baud for Dolby AC-2
NO PAR	Parity: no parity for Dolby
1 STOP	Stopbits: 1 STOP for Dolby
8dAtA	Data bits: 8 for Dolby
OFSt1	One-Way Encode/Decode offset added to TC sent: 01 =1 frame, 02 = 2 frames*
OFSt2	Two-Way Encode/Decode offset added to TC sent: 03 =3 frame, 04 = 4 frames*
Snd Rdr1	Source of TC Sent over ISDN: Usually Snd Rdr1 for Master.

*These are the offsets selected by the ISDN OFFSET/TWO-WAY button on the front panel and trimmed by the Trim- and Trim+ keys on either side of that button. Make this offset in the menu via the SET mode or by the Trim buttons. The same effect is achieved. A positive offset will retard the remote Slave video to match the encode/decode delay of the Dolby codecs.

A Simple Example:

If the ISDN Offset is 02, and if Master code read by the Master IS-1 is 1:00:00:00, then the Slave machine will locate and sync to 1:00:00:02 when moving in Chase mode.

A Not So Simple Example using both ISDN Offset and Local Offset:

If the Master code is 1:00:00:00 and the tape you want to slave has 8 hour time code, the offset will need to be 17:00:00:02 because the Slave reading will “wrap around” at 24:00:00:00 to yield a Slave locate point of 1:00:00:02. Use the Local Offset for the 17:00:00:00 and the ISDN Offset for the 00:00:00:02. The Offset achieved will be the sum of the two.

Remember: ISDN Offsets are viewed in the Serial A Menu, Local Offset in the Serial B Menu (see next page).

The Serial B, Machine Control Connection

Serial B is the RS-422 connection via 9-pin D connector from the IS-1 to the controlled Slave deck. These settings may change slightly depending on the type of machine used, but most 9 pin controlled video machines will operate similarly to the VO-9850 or BVU-800.

Example: Set Serial B (9-pin RS-422) Conf. Parameters:

Press SET, then both Arrow buttons

Select SERIAL B with left or right arrow, then press both Arrows

Scroll through Parameters by left or right Arrows, choose values for each Parameter by DEC/INC buttons.

bVU800	Machine types	0 INPUT 1 bVU800 2 VO9850 3 PU2800 4 SSL 55 5 dA-88 6 r-dAT (Select the one you need)
Ser POS	Slave Position: SerCode (9 pin serial code), or TACH/LTC	Note: This is the source of location shown in SLAVE Display (use TACH/LTC for Aux B timecode input if Slave machine cannot output its timecode over the RS-422 9-pin)
rEC OFF	disable remote record; (or record audio 1, 2, or both)	
SYNC ALL	Sync All/ SY O-lap/Sync END	
LOFST 00	Local offset (Local Slave plugged into the Master IS-1 RS422 Serial B port, refer back to discussion of Offsets, p9)	
PLAYd 07	Play delay	
PAr-o 00	Park Offset	
LOCATE02	Locate Speed (0=Tapeless, 02 Normal, 04 Slow)	
USE LOC	Use LOCATE or SHUTTLE capabilities of local deck	
SHtSPd30	Maximum Shuttle Speed	
tr45 05	Number of tries to sync before giving up (5 is Normal)	
Conn Mid	timecode phase (MID frame or StArt of frame)	
Error 04	error window for sync tries	
No CHASE	USE CHASE/NO CHASE command in the Slave Deck (that is, use the internal synchronizer in a deck rather than the IS-1's synchronizer, a DAT machine with a built in synchronizer, for example)	
RD-4 A-U	This is for Record arming, ignore for sync operations	

Example: Set Serial B Conf. Parameters, cont.

POSLTC	Slave Position: POSLTC/VITC/TIMER 1/TIMER2
	Note: this is the command used by the IS-1 to the Slave deck

to get Slave tape position. In machines with an internal reader this will be POS LTC to get location from the LTC track on the tape. If no reader, use POS Tnr1.

Also Note: latest versions of the firmware have a few more choices here: POSLTC/Tin 1/VITC/L-V/LVT

BVU-950 BVH-1100/BVU-950/DA88 track arming. not required for ISDN synchronizer; setting has no effect for this application. (usually BVU-950)

Also Note: latest versions of the firmware have a few more choices here too:

BVH-1100/BVU-950/DA88/nnc-1/PCM 7030/Fostec

USING the IS-1 to control a video deck without a TC card

(BVU-800, VO-9800 or 9850).

Since no TC is supplied on the Serial B (9pin) connection to the IS-1 from the slave deck, plug LTC from audio track 2 into the Aux B input.

Select Tach-LtC in Serial B menu, (not Ser POS)

Choose POS TMR1 instead of POS LtC

The IS-1 uses the tape timer on the VCR to determine the slave position.. The IS-1 will then read time code from the Aux B input, read the position of the VCR by reading the tach timer and calculating an appropriate offset to convert the timer position to a timecode location.

Before going into the CHASE mode, initialize the Aux B reader and slave deck for use with LTC by taking the IS-1 out of CHASE, or switching the Slave machine to local and issuing a PLAY command. Let it play for a few seconds to get a good code read, then stop. The Slave position information in the display should now be correct even when there is no LTC coming into the Aux B input (for example in Stop, FF, or Rewind).

The machine type selection at the end of the serial B list (BVU-950, BVH-1100, DA-88, etc.) is for track record arming and has no effect on the IS-1 synchronizer application.

Appendix I Sync Light and Mute Logic Output

Starting with software released on Oct 7, 1998, the IS-1 ISDN synchronizer now includes a front panel indicator light for SYNC play condition. This LED, labeled **Col.** on earlier units and unlabeled on later units, is the bottom LED in the **STD.** Column. When an RS422 controlled deck is slaved to the IS-1, this LED will come on when the slave deck is playing forward and locked to the synchronizer timecode. There is also a logic output (5v TTL) on the Serial A DB-9: Pin 9 on the DB-9 will go high referenced to pin 4 and 6 (Gnd.) when the deck is in the locked play condition. Properly interfaced, this logic output may be used to “un-mute” the monitor speakers, thus providing a Rewind or Fast Forward dim or mute to avoid unpleasant sounds or blown tweeters which may result in customer dissatisfaction.

Illustrative Connection Diagrams

Figure

- 1 Two IS-1s, Basic Timecode Send/Receive
- 2 Two IS-1s, Slave Remote VCR w/ internal TC Reader
- 3 Two IS-1s, Slave Remote VCR w/o internal TC Reader
- 4 One IS-1, Slave to Audio Timecode
- 5 Wiring and Notes: Serial A Cable

Figure 1

Basic Connection: Two Colin Broad IS-1 ISDN Synchronizers Sending/Receiving Timecode

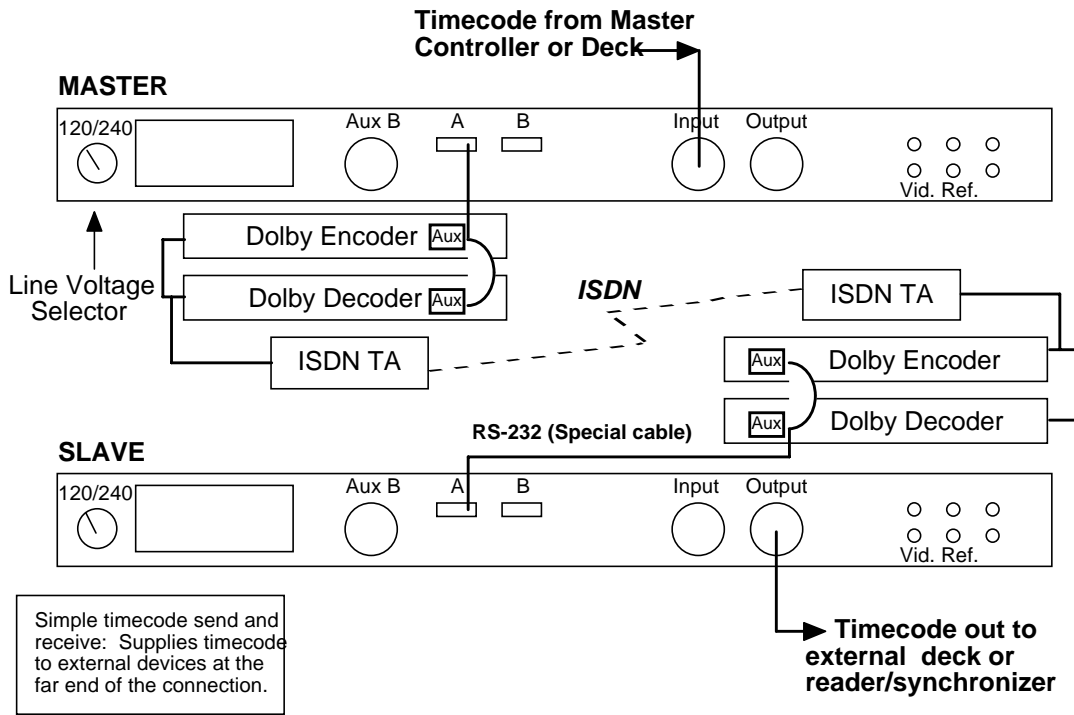

Figure 2

Basic Connection: Two Colin Broad IS-1 ISDN Synchronizers Sending Timecode, Slaving a VCR

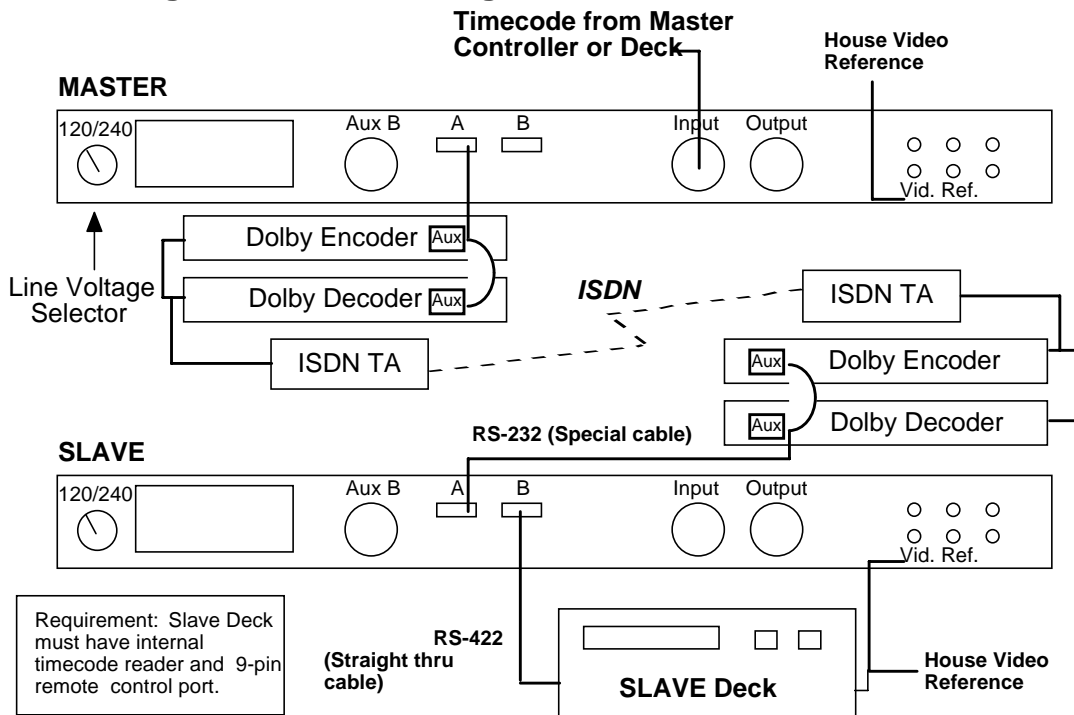

Figure 3

Basic Connection: Two Colin Broad IS-1 ISDN Synchronizers Sending Timecode, Slaving a VCR Having No Internal Reader

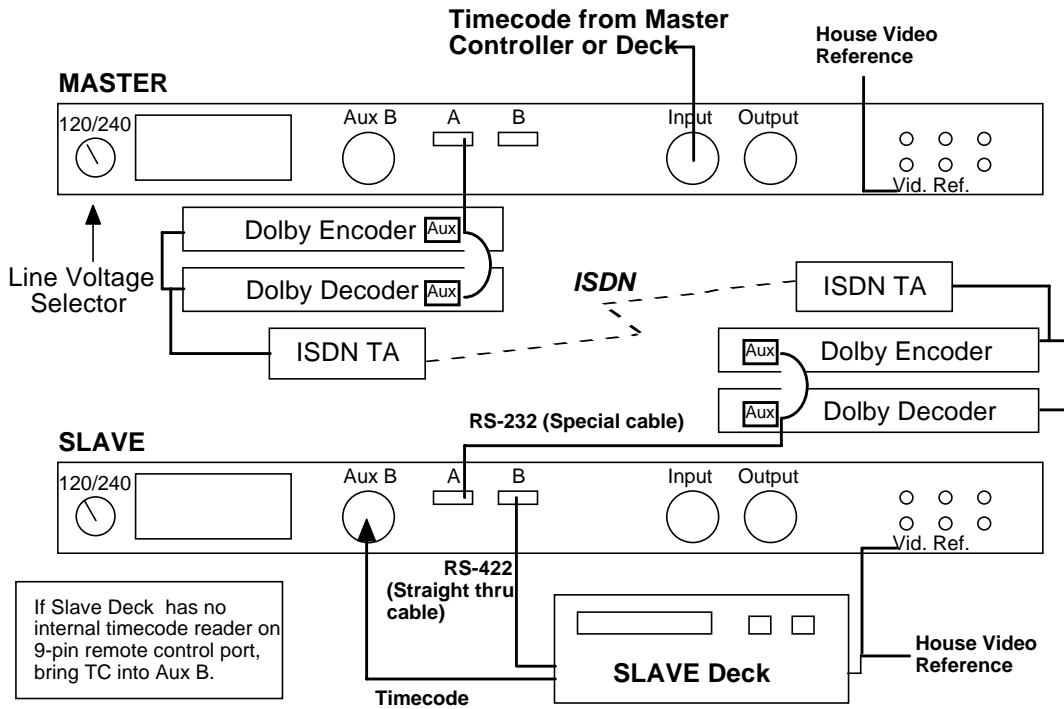

Figure 4

Basic Connection: One Colin Broad IS-1 ISDN Synchronizer Receiving Audio Timecode, Slaving a VCR

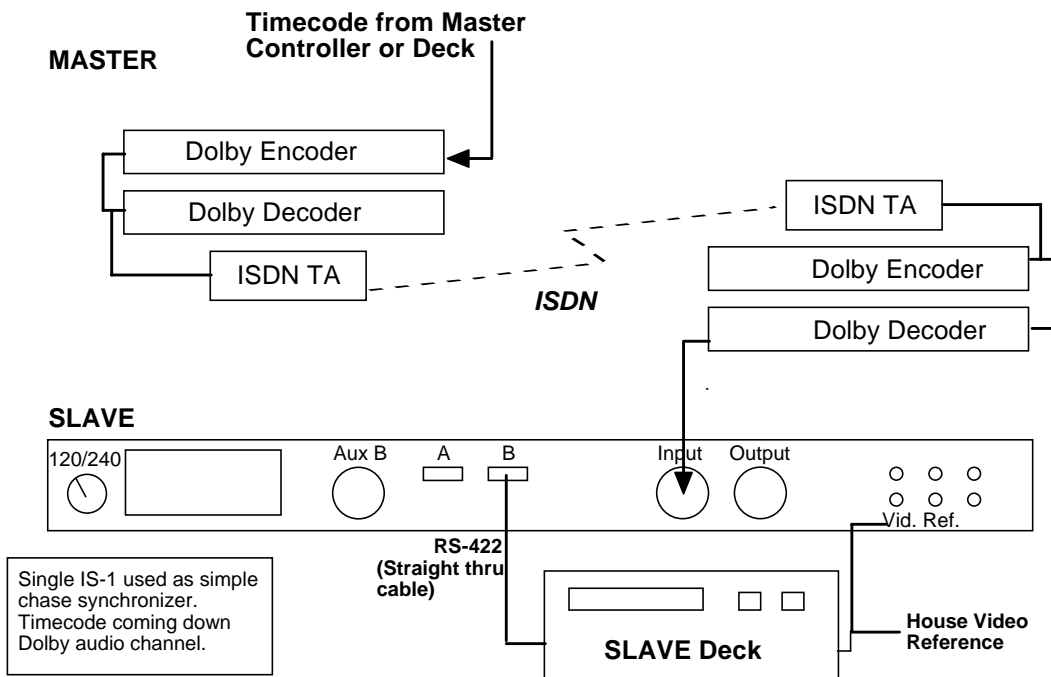

Figure 5

Serial A Cable

Colin Broad IS-1 to Dolby Aux Data Serial Ports

Revised 1/30/98 for compatibility with
Dolby DP523/524 and DP503/524 units

Dolby Dec. DP502/524 DB9 Male	Dolby Enc. DP501/503/523 DB9 Male	CB IS-1 "Serial A" DB9 Female
pin #	pin #	pin #
2		3
	3	2
5	5	4

All connectors in sequence, wire lengths as below:

DB9 M <12 inches> **DB9 M** <36 inches> **DB9 F**

Note that earlier versions of this cable were supplied with duplicate connections for encoder and decoder DB9 Males. This works only with Dolby DP501 and DP502 units. For use with DP523, 503, and 524 units, only pins 3 and 5 are connected to the Encoder and pins 2 and 5 to the Decoder, as listed above.